

**Día del
Medio ambiente
5 de junio 2026**

**Autosuficiencia
energética
en puertos**



GENERACIÓN UNDIMOTRIZ PUERTO DE VALENCIA Andrea Novás Cortés

ROTARY WAVE

Somos una start up, que desarrolla soluciones innovadoras en el campo de las energías renovables marinas.

- Equipo joven y multidisciplinar
- Instalaciones
- Tecnologías patentadas

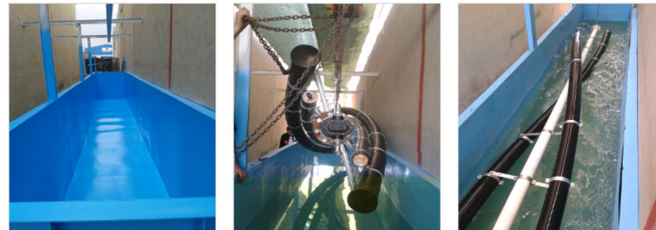

GENERACIÓN UNDIMOTRIZ PUERTO DE VALENCIA ROTARY WAVE

NUESTROS DISPOSITIVOS

SMART PUMP: encargada de transformar el movimiento de giro del eje en agua presurizada

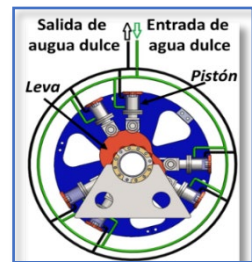

CONVERTIDOR DE ENERGÍA UNDIMOTRIZ: Es un dispositivo que va anclado al dique para generar electricidad y/o desalar agua a partir de la energía de las olas

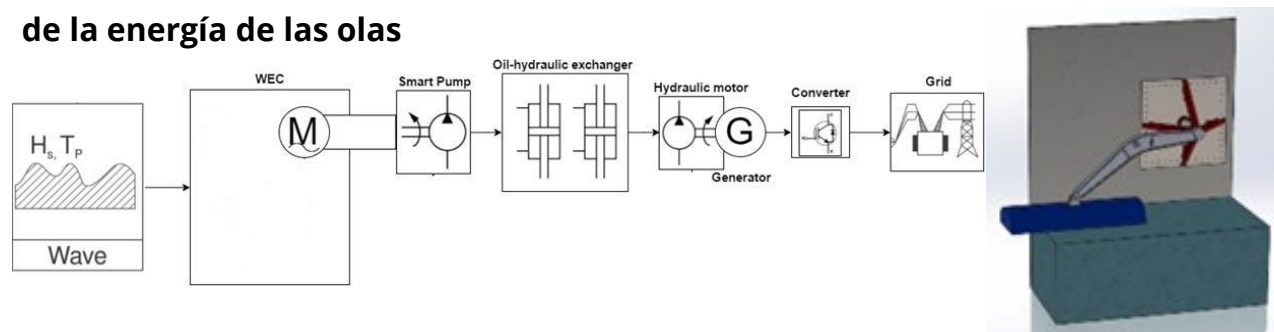

GENERACIÓN UNDIMOTRIZ PUERTO DE VALENCIA ROTARY WAVE



ENERGÍA LIMPIA DE BAJO COSTE



MATERIALES COMUNES COMERCIALES



SIN EMISIÓN DE CO₂ Y GASES



MANTENIMIENTO SIMPLE Y SENCILLO



MATERIALES RECICLABLES



AMBIENTALMENTE RESPETUOSA



SIN ACEITES



ELECTRICIDAD PRODUCIDA EN TIERRA



PROYECTO MATCH UP

El objetivo general del proyecto se centró en el diseño e implementación de un sistema convertidor (WEC) que transformaba la energía de las olas en energía eléctrica.



PROYECTO MATCH UP

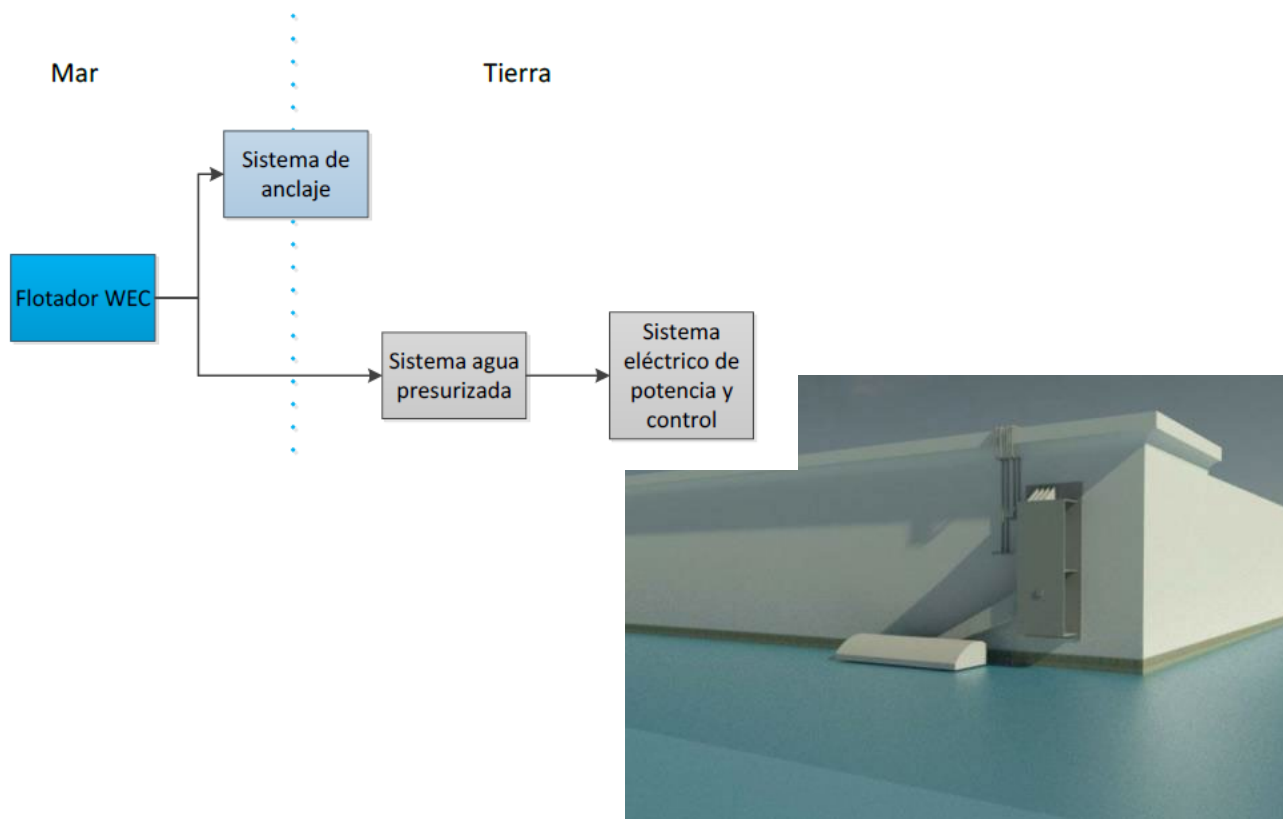

PROYECTO MATCH UP

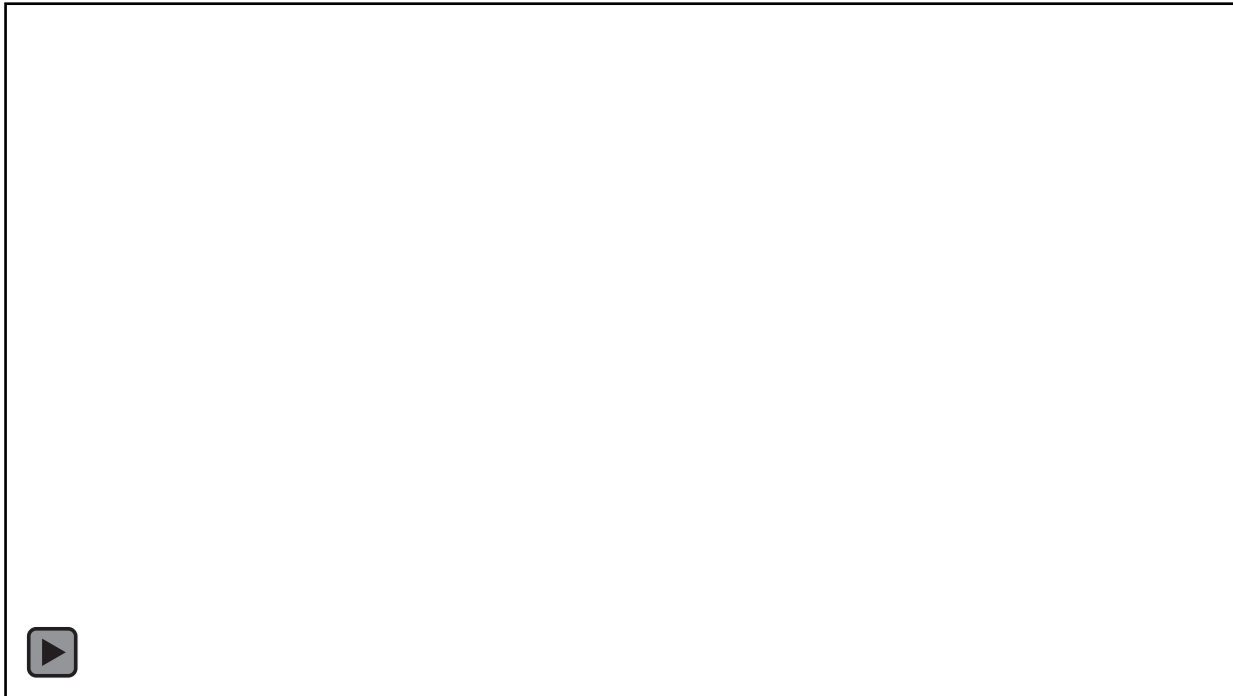

PROYECTO MATCH UP

FLOTADOR

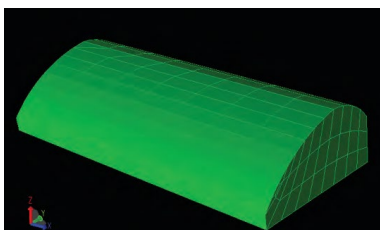
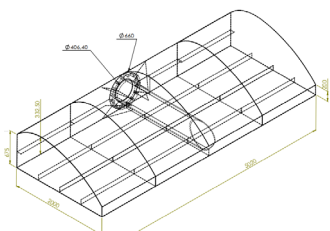

BRAZO

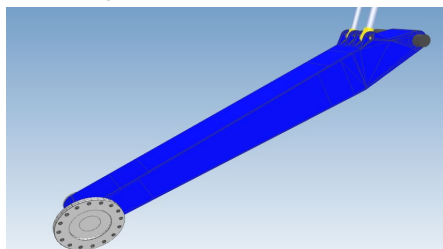
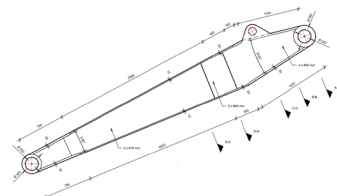

BASTIDOR

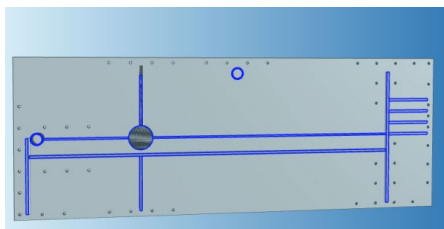
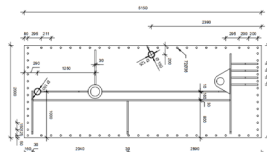

PROYECTO MATCH UP

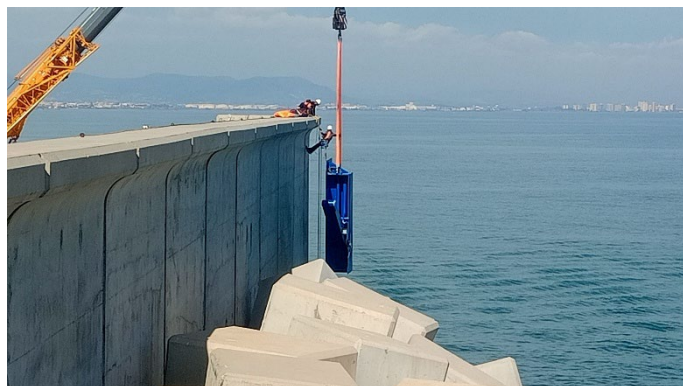

PROYECTO MATCH UP



PROYECTO MATCH UP

RESULTADOS

Durante las experiencias realizadas en el puerto de Valencia, con el convertidor de energía undimotriz se han generado 11,5MWh

Wave height	Peak period (s)	No. of Samples	% of the total Samples	average height (cm)	Average Peak Period (s)	Average Energy Generated per day (kWh)	Daily energy x No. of samples (kWh)
<0,5	2	8	0,0327	23,22	2,07	6,16	49,26
<0,5	3	7	0,0286	14,63	2,97	10,76	75,32
<0,5	4	13	0,0531	19,23	3,98	9,25	120,26
<0,5	5	8	0,0327	17,92	4,90	15,18	121,41
<0,5	10	1	0,0041	18,33	9,81	10,30	10,30
0,5	2	7	0,0286	34,58	2,22	6,90	48,30
0,5	3	18	0,0735	37,25	3,09	15,96	287,36
0,5	4	38	0,1551	42,60	4,08	23,96	910,38
0,5	5	48	0,1959	48,09	4,96	40,98	1967,11
0,5	6	36	0,1469	51,07	5,92	47,86	1723,07
0,5	7	11	0,0449	48,53	7,04	44,97	494,63
0,5	8	6	0,0245	64,06	7,83	58,40	350,42
0,5	9	5	0,0204	50,00	8,80	62,48	312,40
0,5	10	1	0,0041	43,96	10,68	39,10	39,10
1	5	3	0,0122	99,21	4,99	90,02	270,06
1	6	11	0,0449	86,12	5,98	117,32	1290,55
1	7	8	0,0327	90,80	7,08	78,54	628,35
1	8	3	0,0122	89,13	8,06	138,25	414,74
1	9	1	0,0041	105,21	9,32	162,52	162,52
1	10	6	0,0245	92,70	9,73	106,65	639,93
1	11	1	0,0041	92,54	10,97	40,85	40,85
1,5	6	1	0,0041	125,79	6,07	171,01	171,01
1,5	7	1	0,0041	125,79	7,10	171,01	171,01
1,5	10	1	0,0041	137,88	10,00	299,46	299,46
2	9	1	0,0041	203,75	9,41	416,19	416,19
2	11	1	0,0041	181,21	10,97	580,65	580,65
Total energy generated during the experience						11594,65	



PROYECTO ENERMARPORT



El proyecto EnerMarPort se encuentra englobado dentro de otro proyecto conjunto cuyo objetivo principal consiste en la creación de una plataforma de ensayo de renovables marinas y demostradores tecnológicos de generación de energía renovable marina en aguas del puerto de Valencia.

- Energías marinas puerto de Valencia
- Bluenewables
- APV



PROYECTO ENERMARPORT



El proyecto **RENMARINAS VALENCIAPORT - EnerMarPort** - Demostrador de undimotriz tiene como principal objetivo la demostración a nivel de planta piloto de un generador de energía renovable undimotriz.

ESQUEMA DEL PROYECTO



PROYECTO ENERMARPORT



IMPACTO ESPERADO

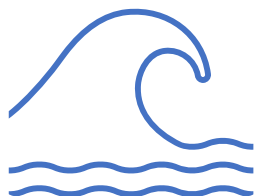

Generación de energía 100% renovable a partir del oleaje



Reducción de emisiones y contribución a la descarbonización

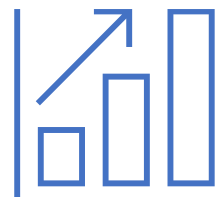

Validación tecnológica para futuros despliegues comerciales



Impulso a la innovación y a la economía azul



PROYECTO ENERMARPORT



El dispositivo ENERMAR PORT se compone de 3 flotadores de 270 kW

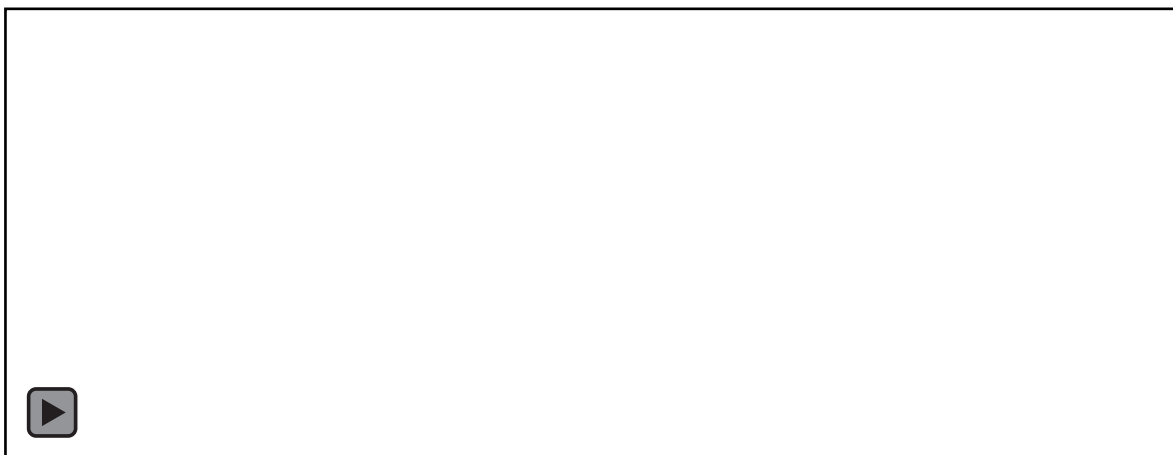

Con esta propuesta, se estima generar 1.000.000 kW/año, para reducir alrededor de 125 toneladas en la producción anual de CO₂ de la ciudad.



PROYECTO ENERMARPORT



Tras analizar las condiciones de oleaje se han efectuado las simulaciones en las diferentes condiciones de operación.

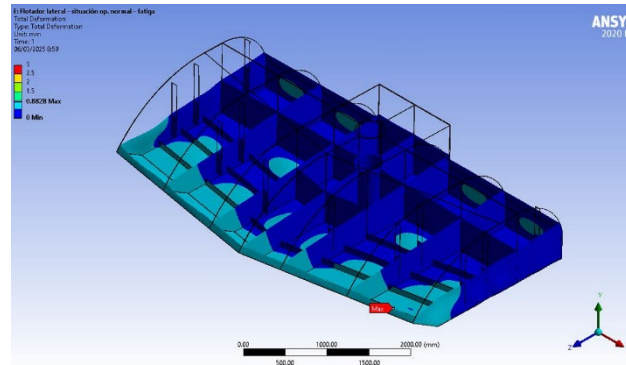
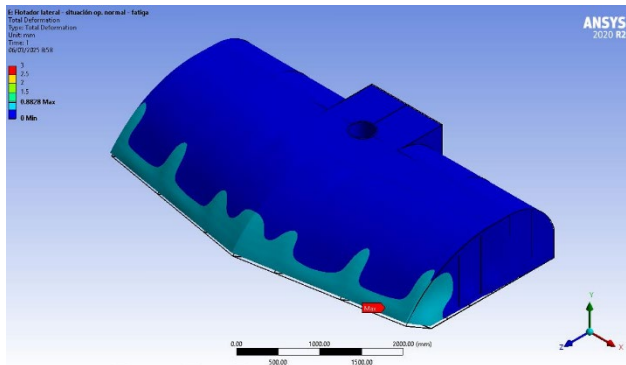

PROYECTO ENERMARPORT

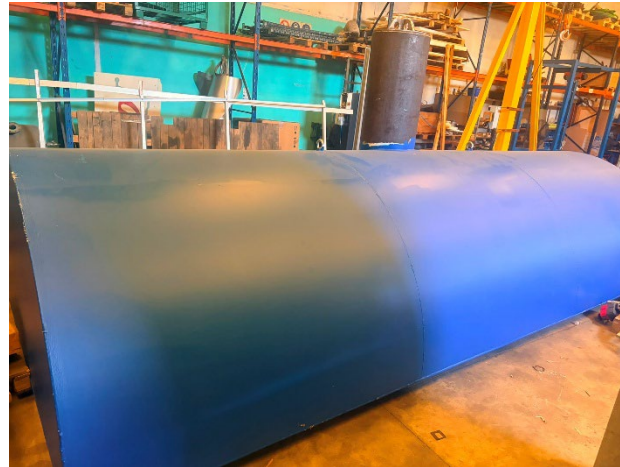
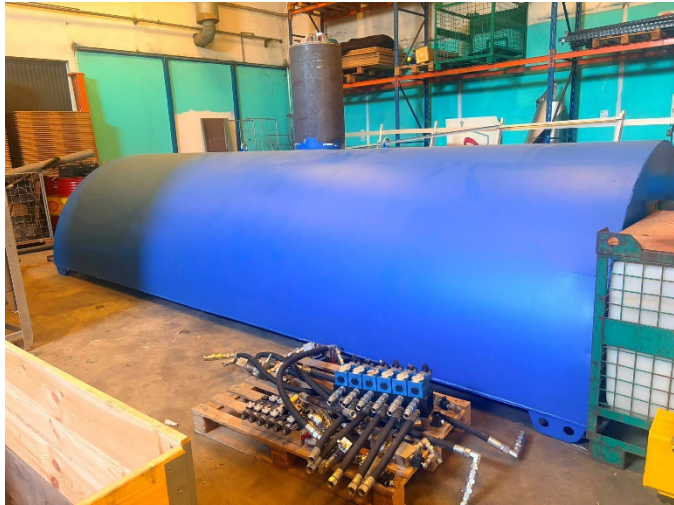

PROYECTO ENERMARPORT

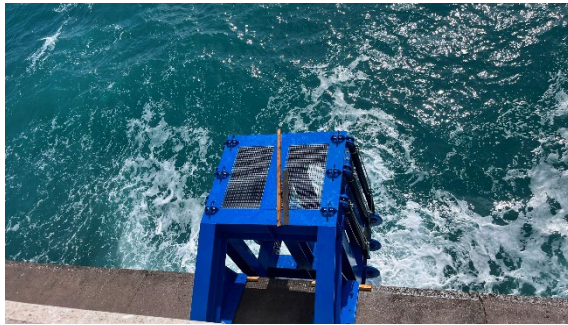

PROYECTO ENERMARPORT



SIGUIENTES PASOS

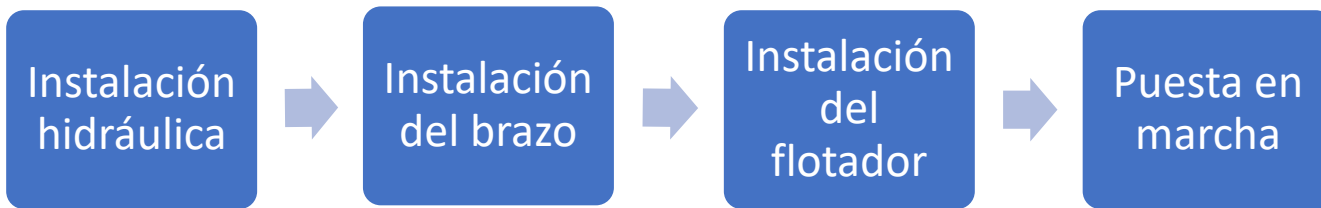

GENERACIÓN UNDIMOTRIZ PUERTO DE VALENCIA

MUCHAS GRACIAS

Andrea Novás Cortés

anovas@rotarywave.com

+34 961176207





DÍA MUNDIAL DEL
MEDIOAMBIENTE
APV

